

Distributed Multiuser MIMO with Full Spatial Multiplexing

Horia Vlad Balan, Ryan Rogalin, Antonios Michaloliakos, Konstantinos Psounis, Giuseppe Caire

Motivation & Introduction

Multiuser MIMO is leaving the theoretical stage and moving towards practical deployment. Current implementations are limited to single access points, since synchronizing symbol timing and phases across different access points has been traditionally seen as too difficult. Here we present the first practical system realization that disproves this idea. We have managed to synchronize different access points within picoseconds in order to provide phase consistency across different transmitters. Using the resulting increase in spatial diversity, we transmit to multiple users with full spatial multiplexing, obtaining large pre-log capacity gains.

Software Radio

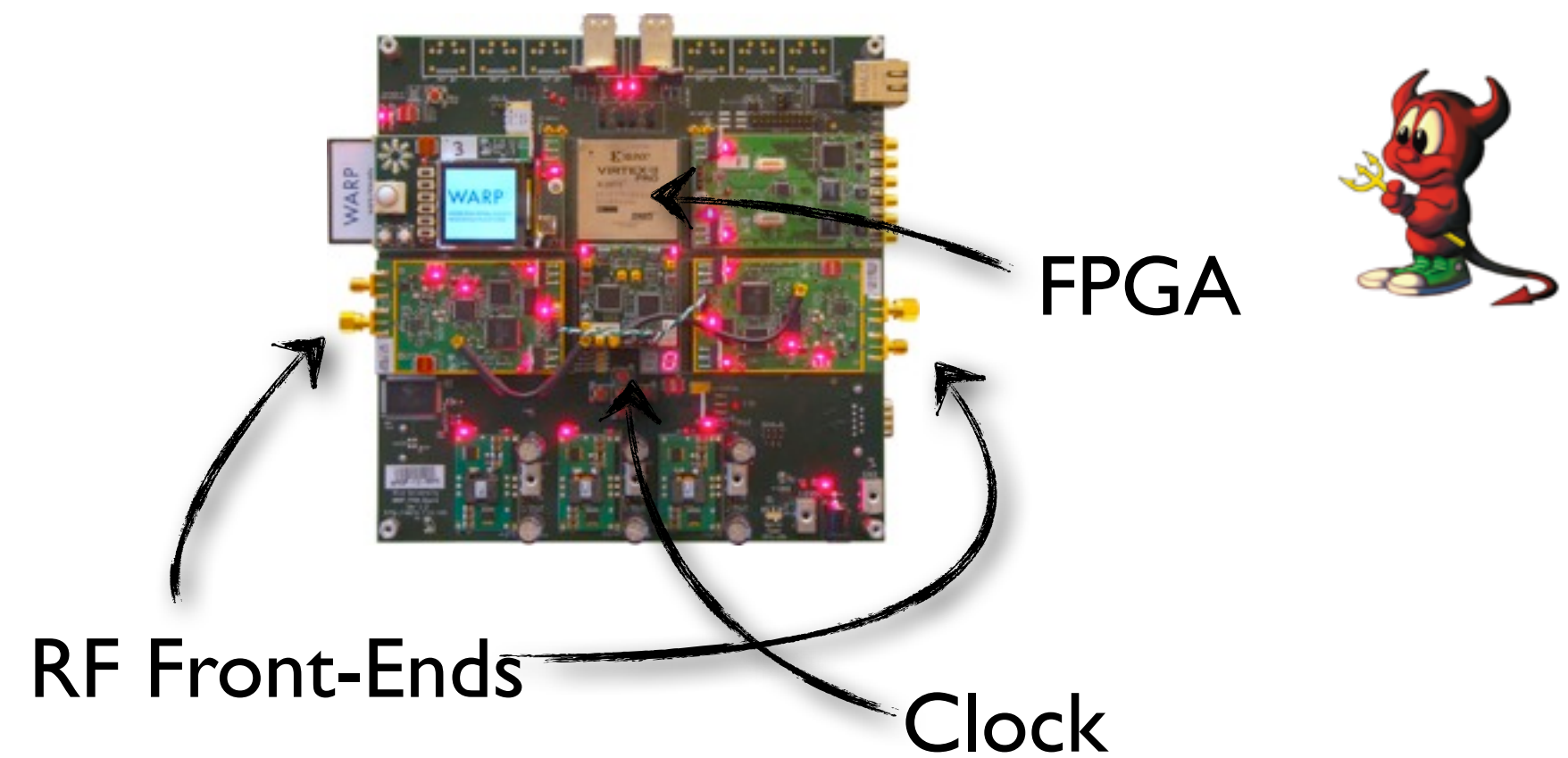

Enterprise WIFI

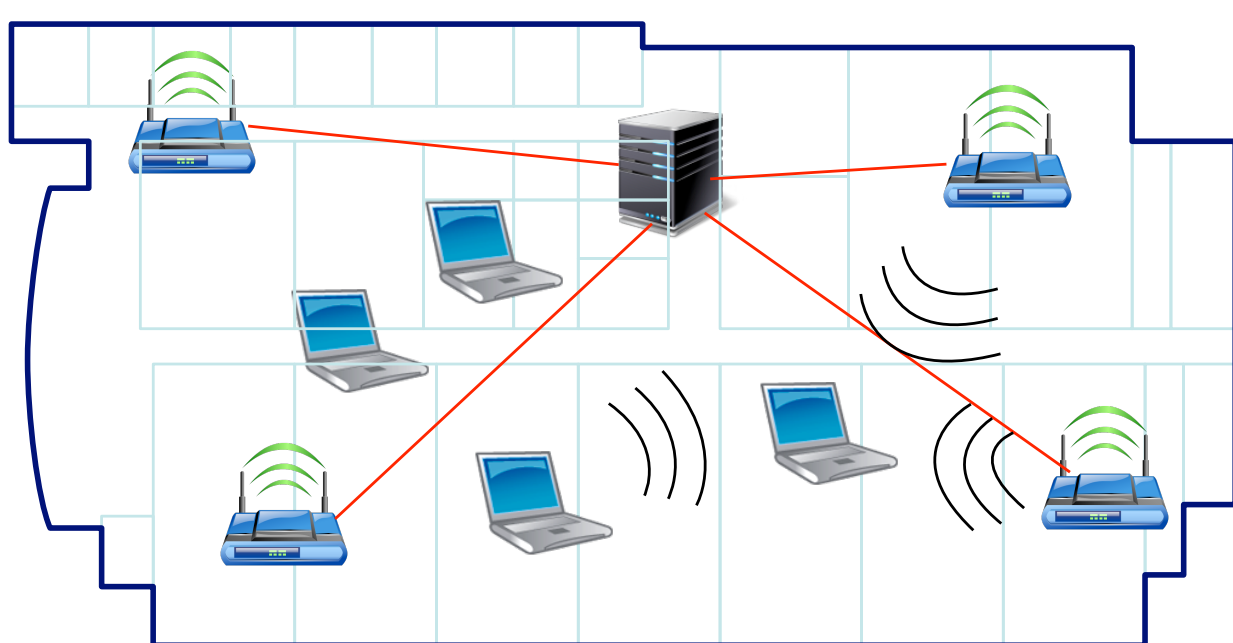

Multiple synchronized access points are controlled by a single server. We would like to achieve a full multiplexing gain in the downlink.

Distributed MIMO

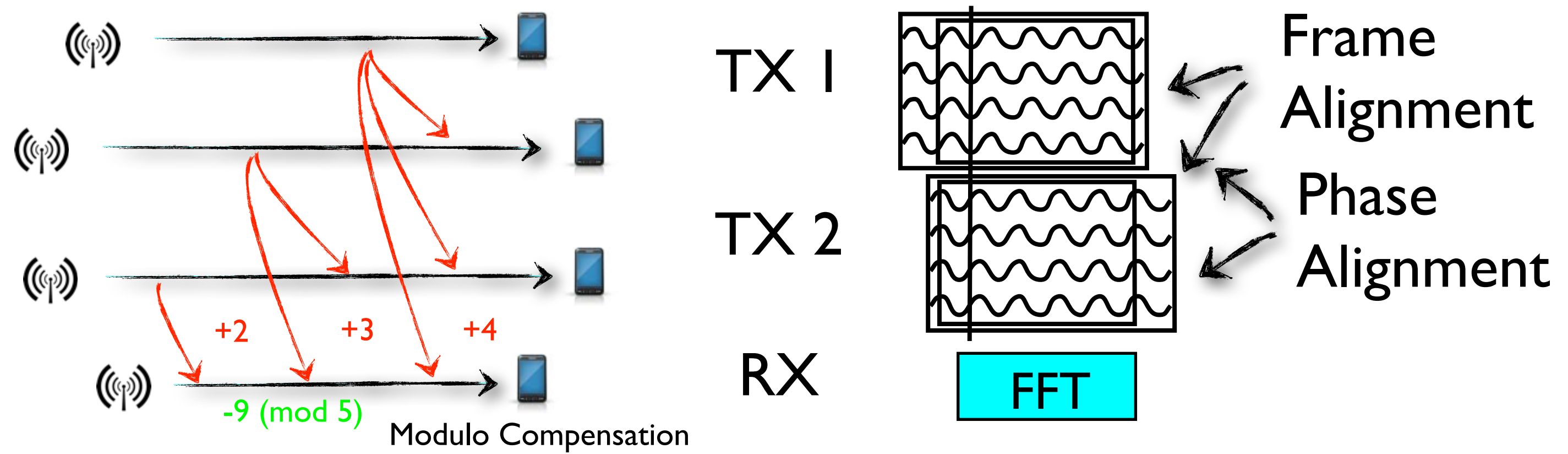

The senders precode their data using Tomlinson-Harashima precoding, creating a separate channel for each user.

The access points synchronize their OFDM symbols within a cyclic prefix interval and synchronize their phases.

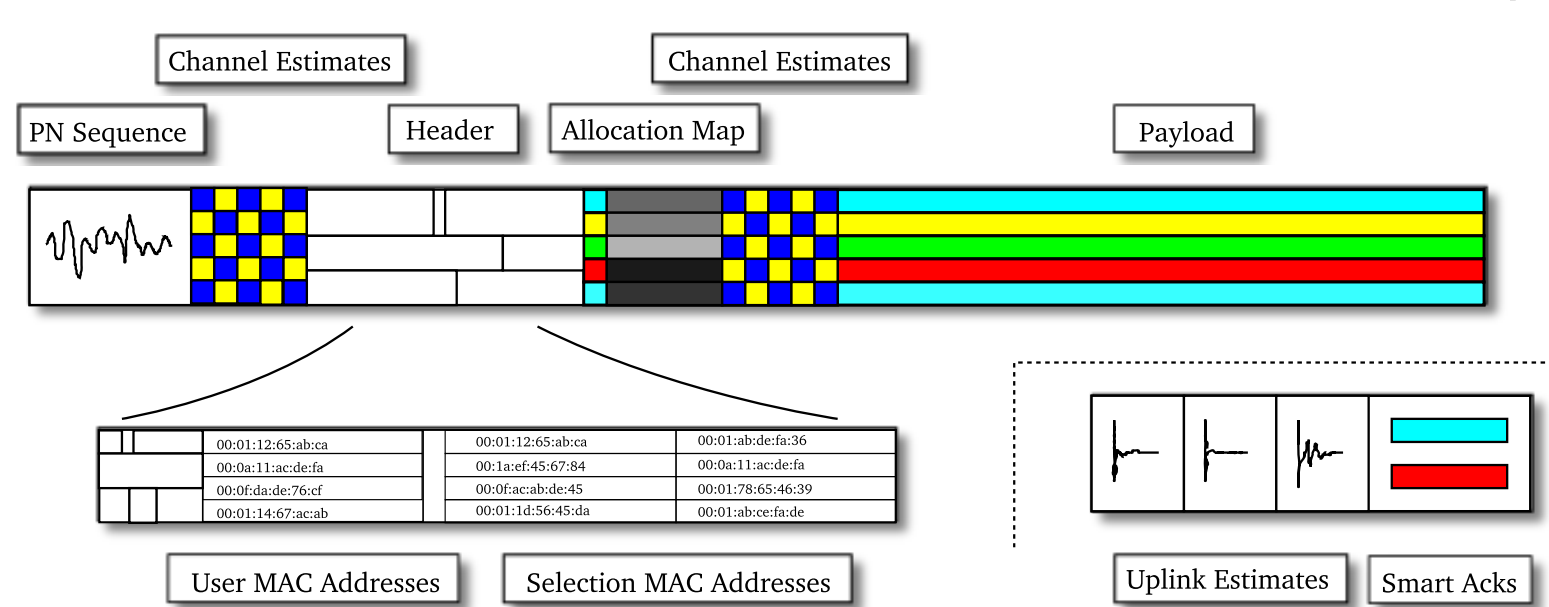

The MAC layer includes a synchronization header, uplink pilots for estimation and low-overhead acknowledgments.

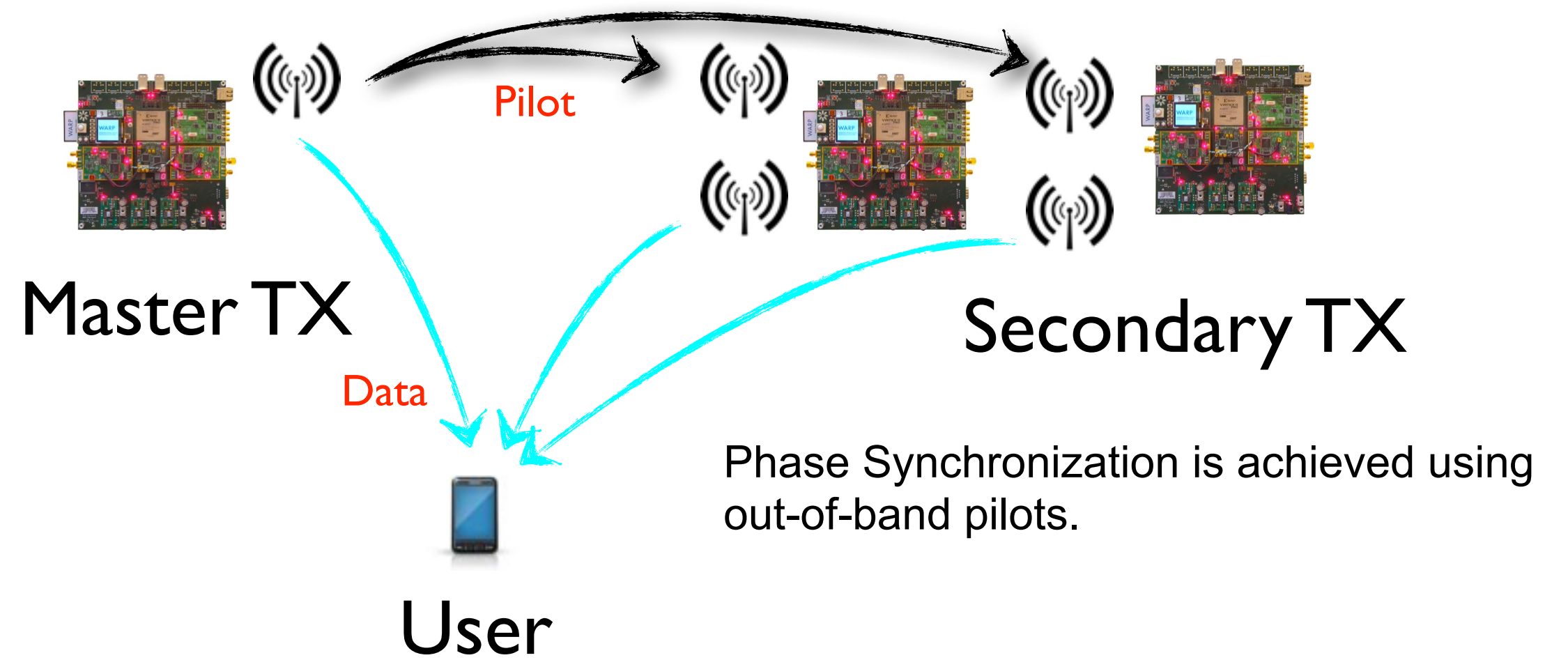

Results

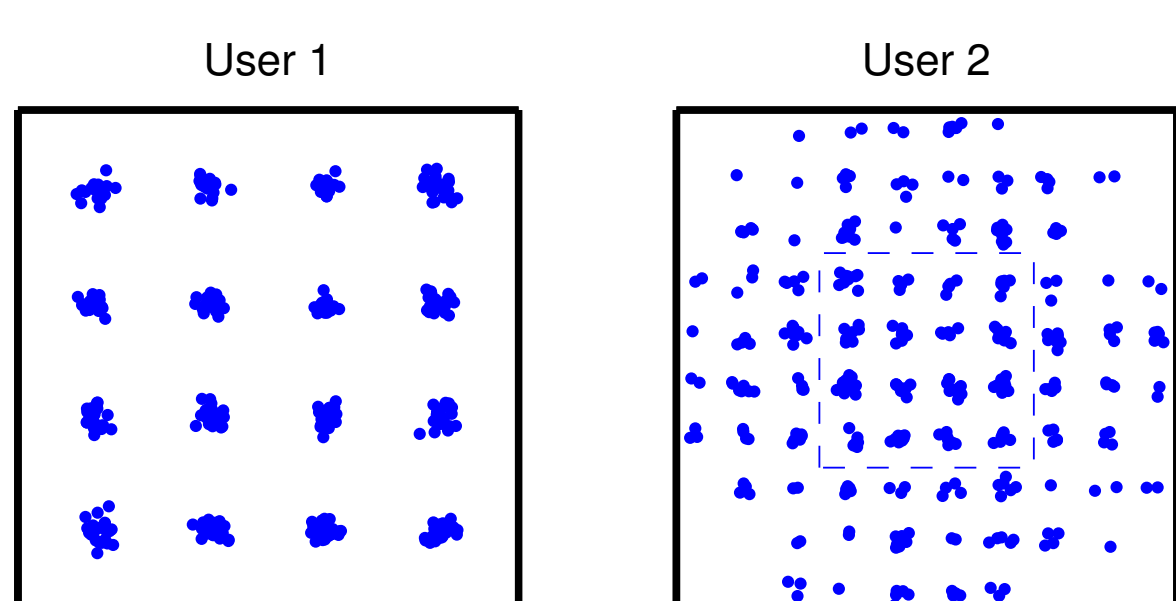

Each user receives an independent stream of data.

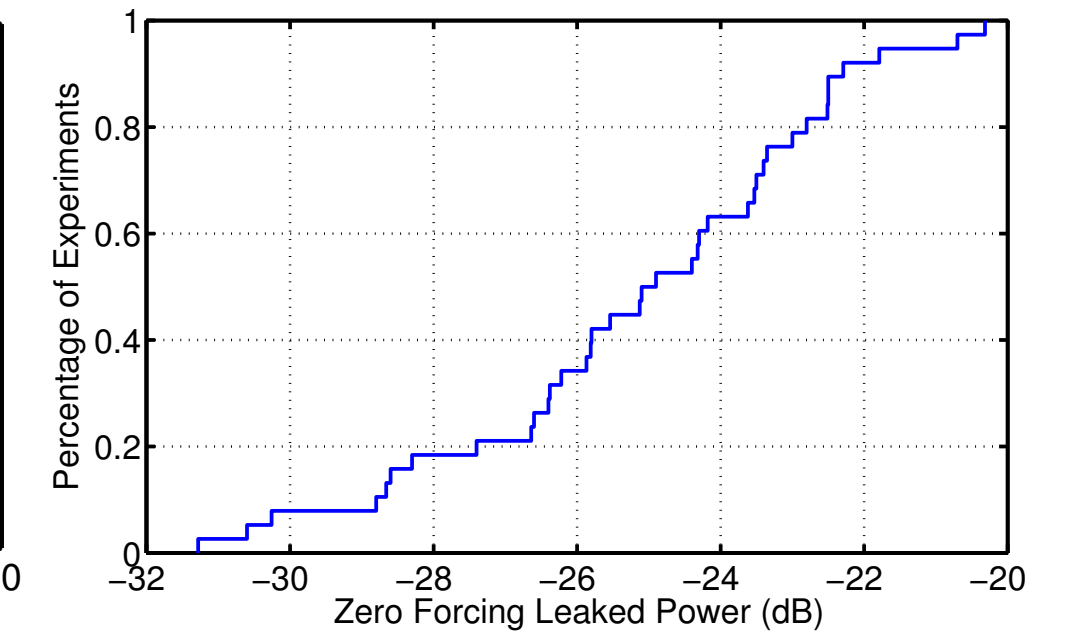
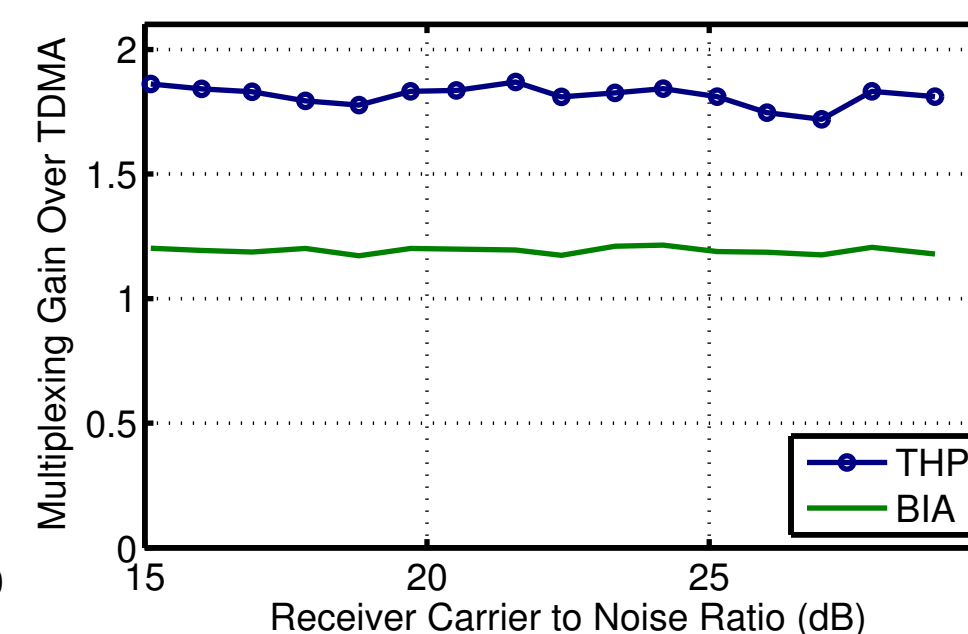
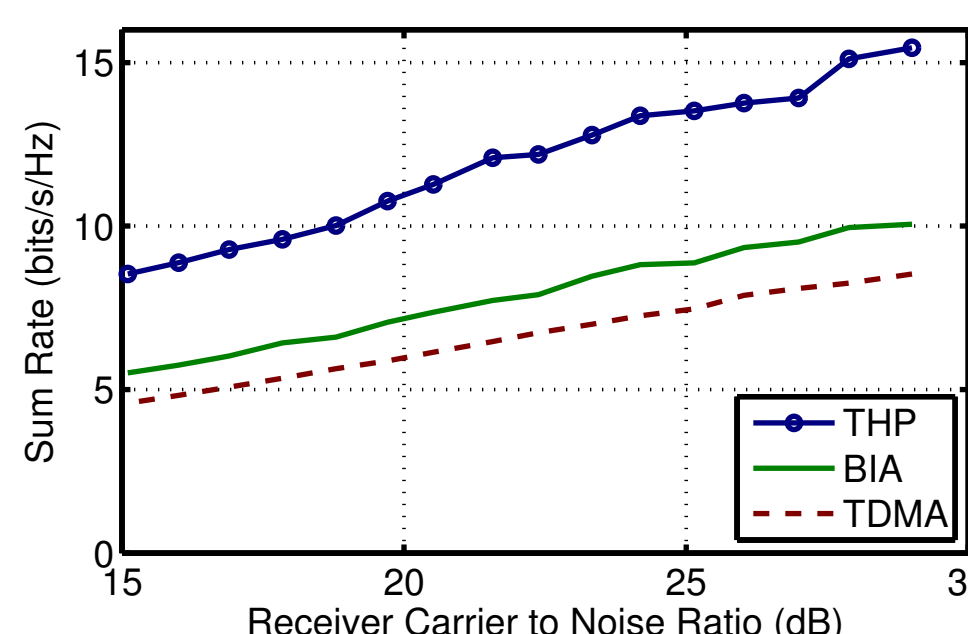

For the same level of transmit power, in a 2x2 scenario we observe an 85% multiplexing gain. The channel separation is better than 22 dB.

See our Demo as well!!!

Distributed Multiuser MIMO with Full Spatial Multiplexing

Horia Vlad Balan, Ryan Rogalin, Antonios Michaloliakos, Konstantinos Psounis, Giuseppe Caire

Motivation & Introduction

Multiuser MIMO is leaving the theoretical stage and moving towards practical deployment. Current implementations are limited to single access points, since synchronizing symbol timing and phases across different access points has been traditionally seen as too difficult. Here we present the first practical system realization that disproves this idea. We have managed to synchronize different access points within picoseconds in order to provide phase consistency across different transmitters. Using the resulting increase in spatial diversity, we transmit to multiple users with full spatial multiplexing, obtaining large pre-log capacity gains.

Software Radio

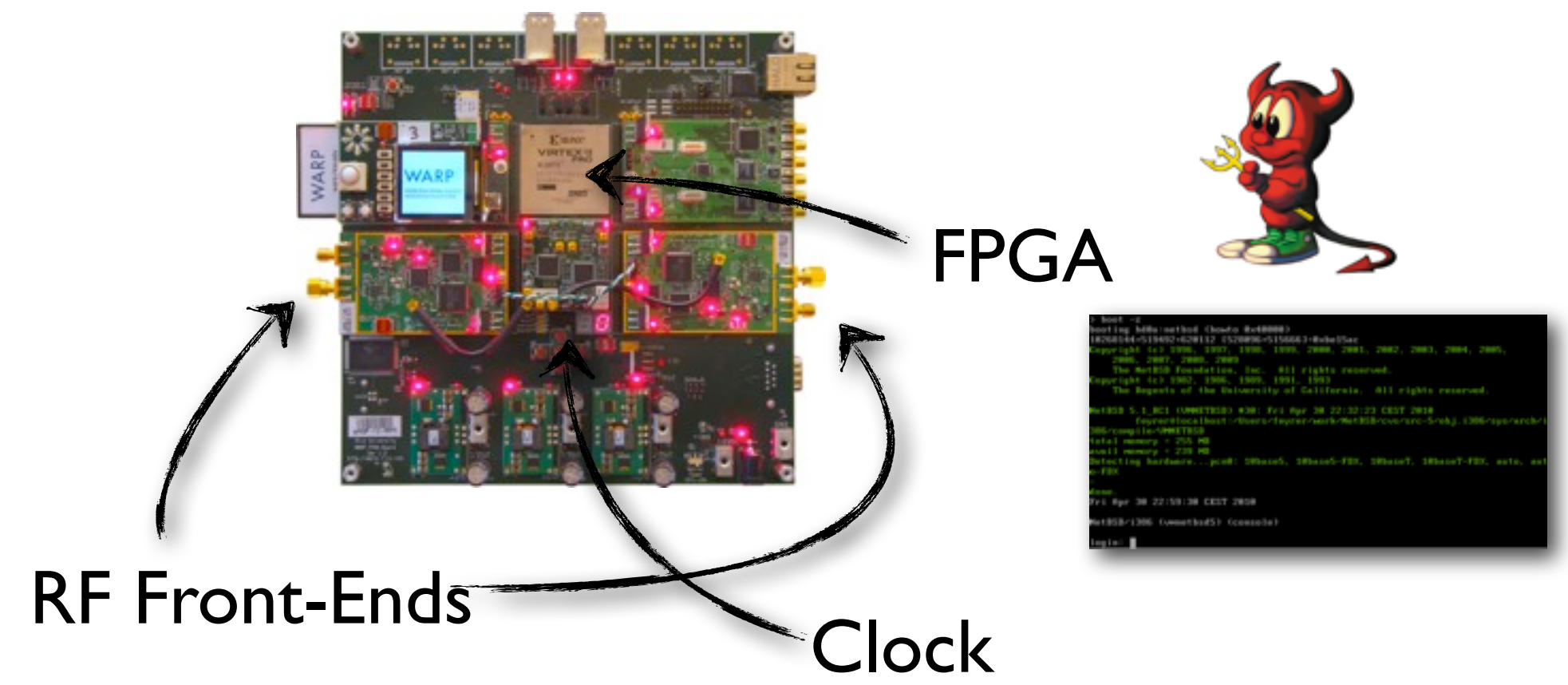

Enterprise WIFI

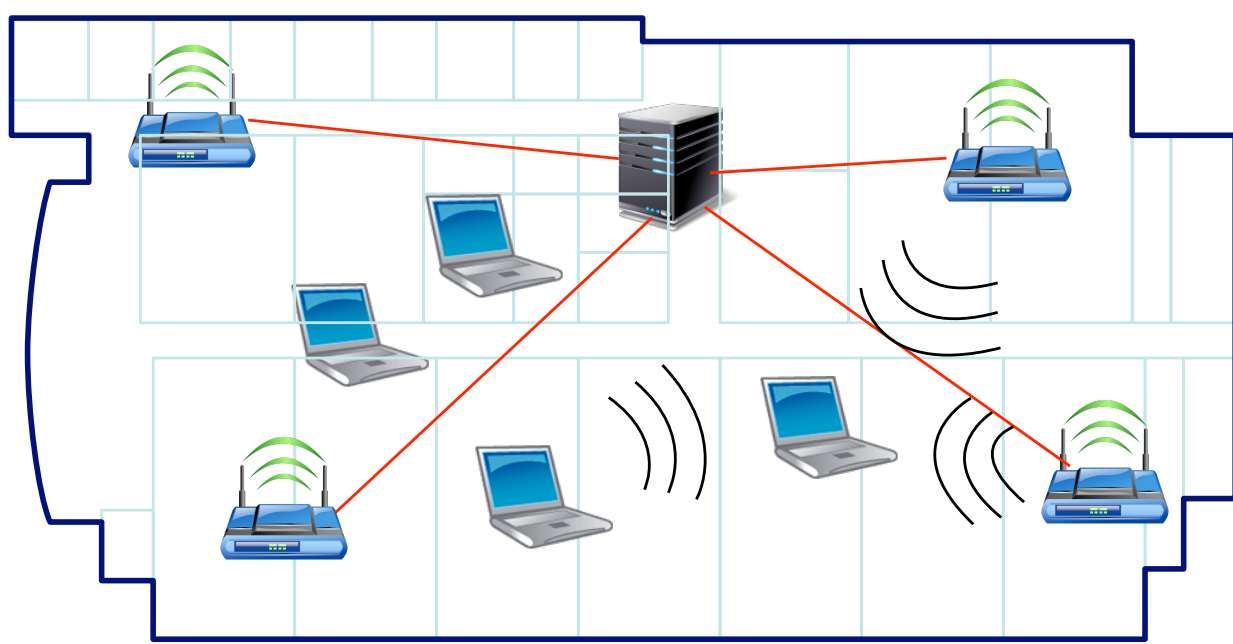

Multiple synchronized access points are controlled by a single server. We would like to achieve a full multiplexing gain in the downlink.

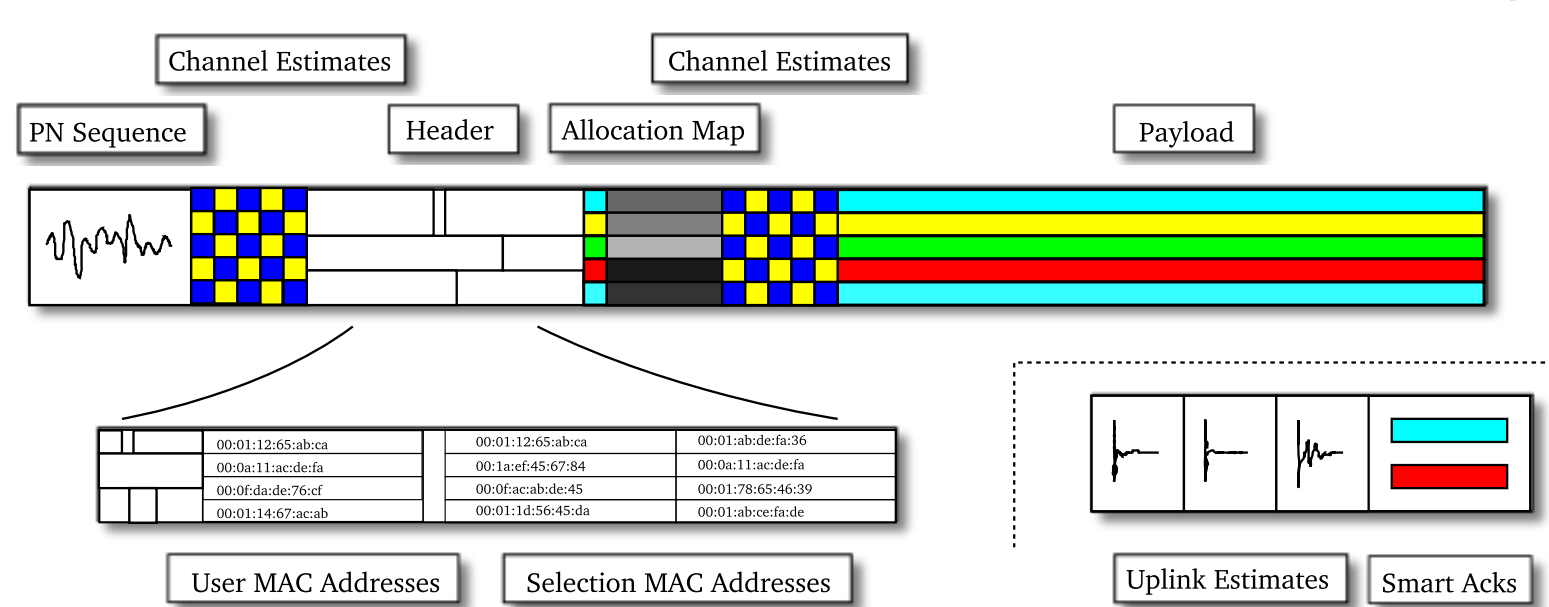

The MAC layer includes a synchronization header, uplink pilots for estimation and low-overhead acknowledgments.

Distributed MIMO

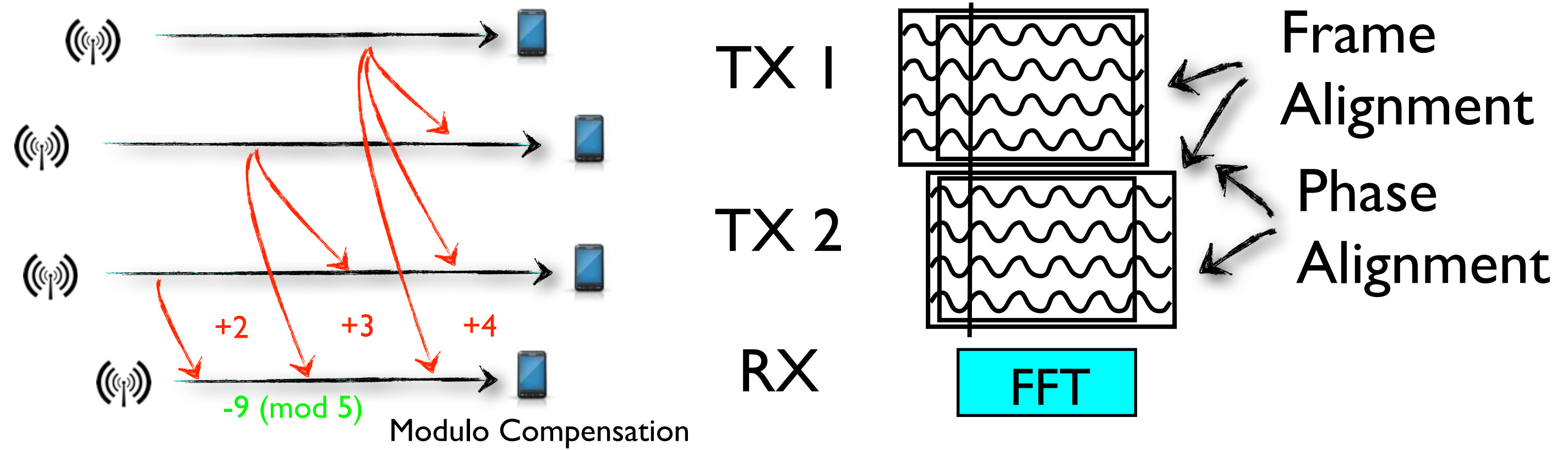

The senders precode their data using Tomlinson-Harashima precoding, creating a separate channel for each user.

The access points synchronize their OFDM symbols within a cyclic prefix interval and synchronize their phases.

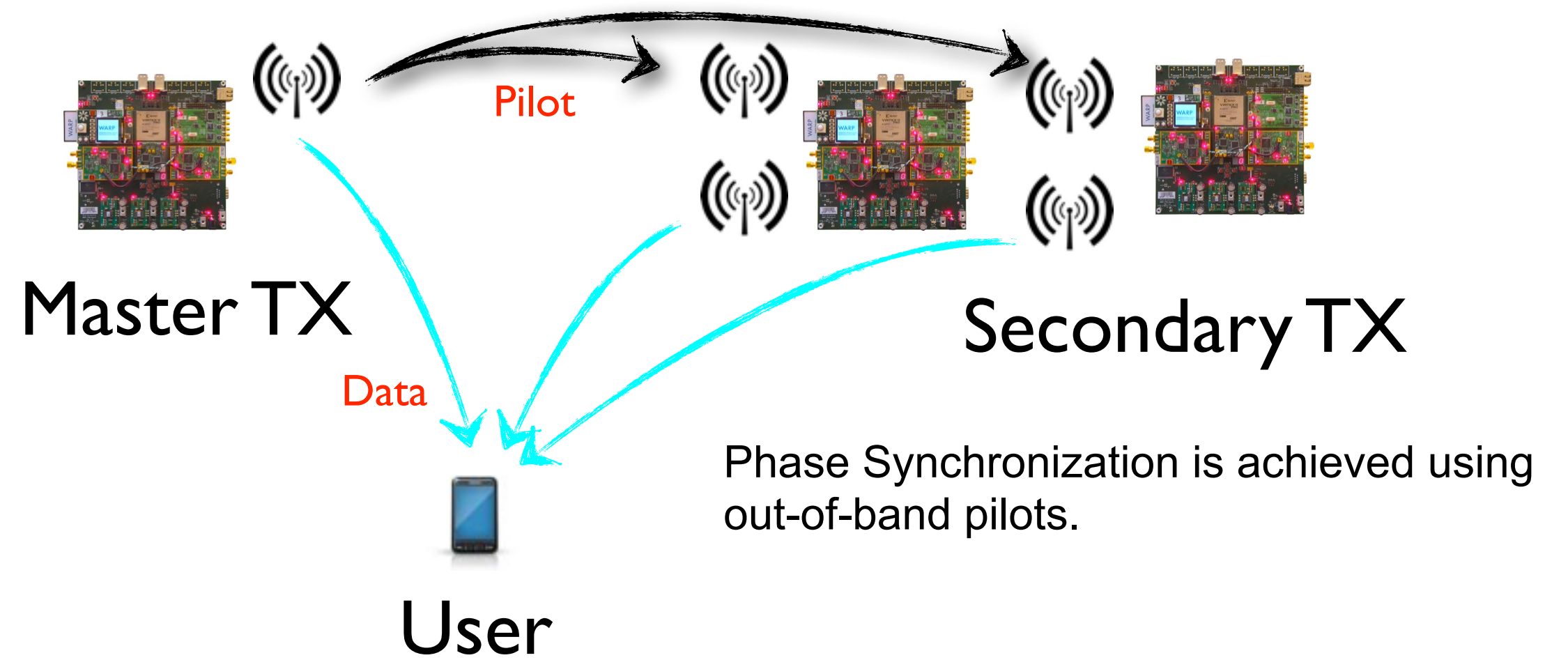

Phase Synchronization is achieved using out-of-band pilots.

Results

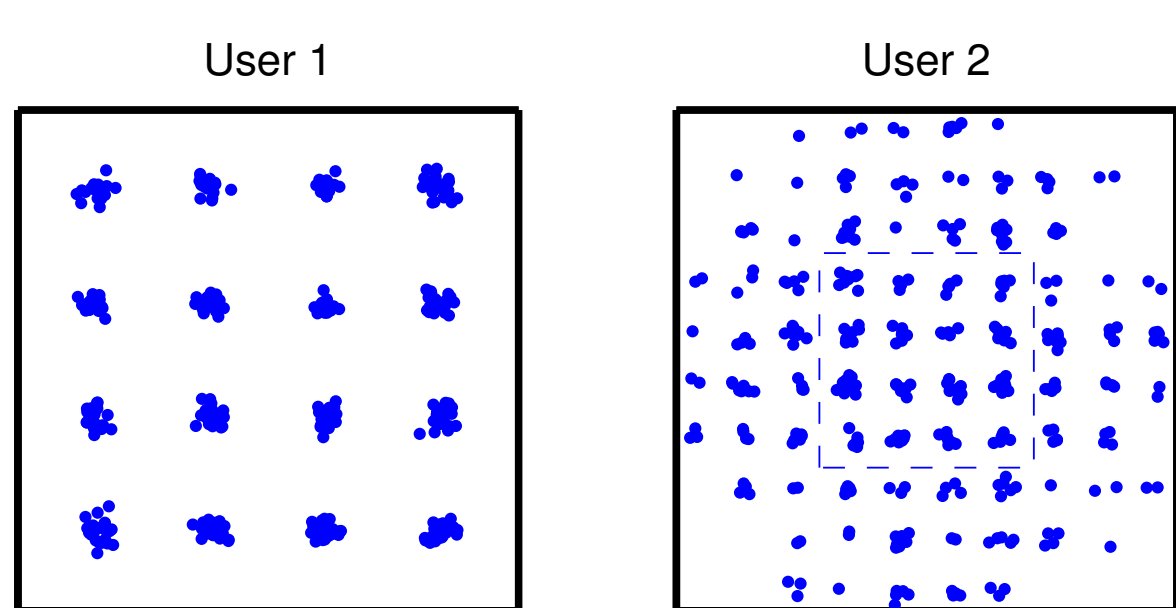

Each user receives an independent stream of data.

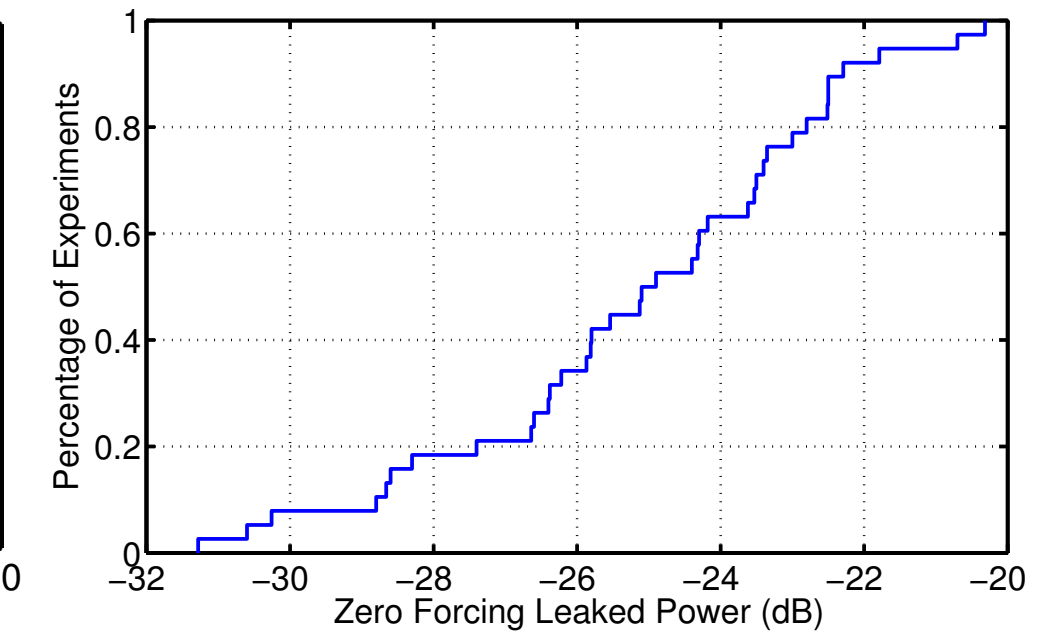
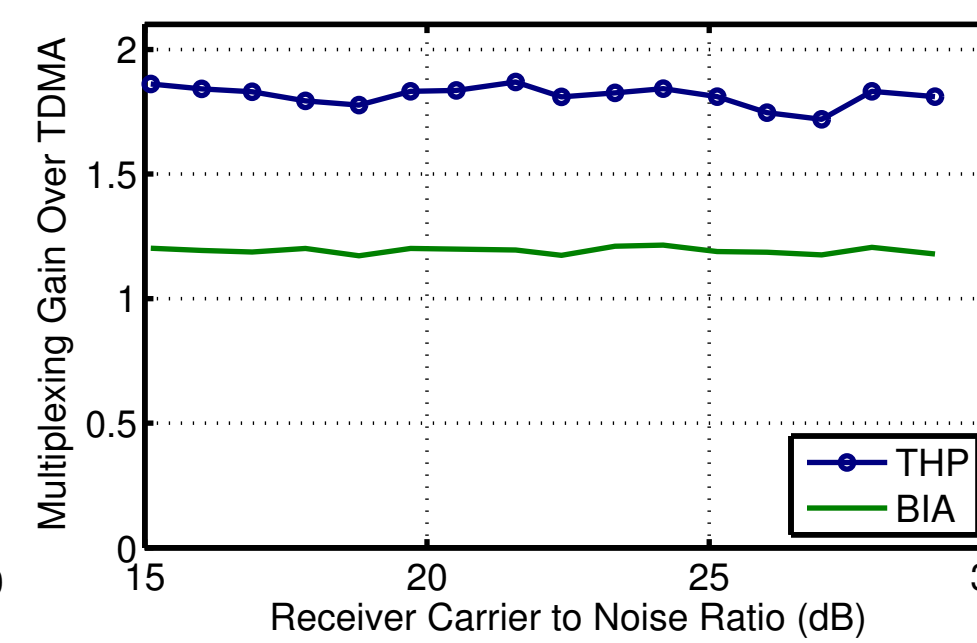
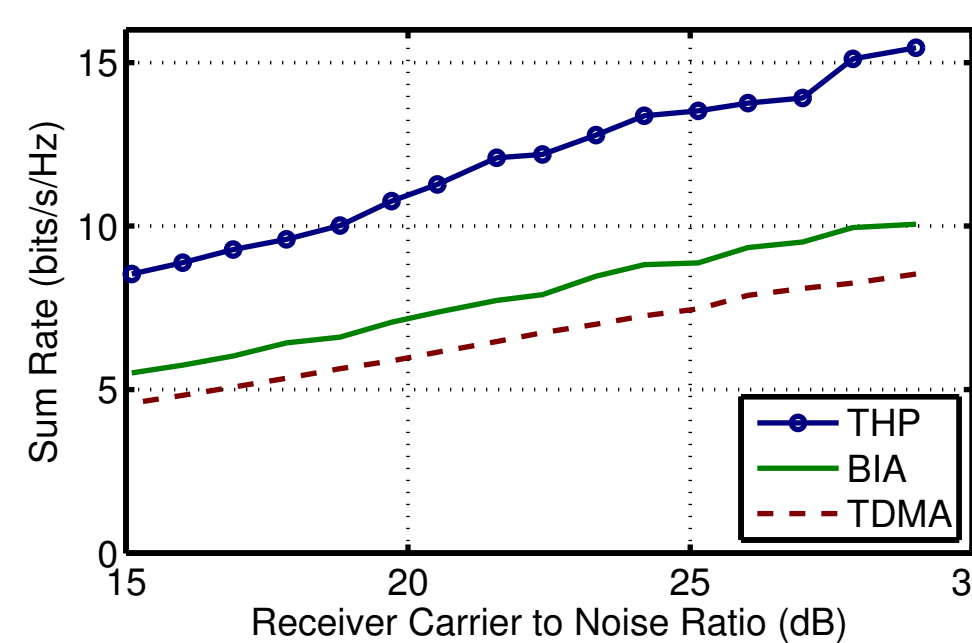

For the same level of transmit power, in a 2x2 scenario we observe an 85% multiplexing gain. The channel separation is better than 22 dB.

See our Demo as well!!!